



MODEL C/FSX

CEILING DAMPER SQUARE AND RECTANGULAR

U.L. 555C CLASSIFIED ASSEMBLIES AND ULC S112.2 LISTED

Approved for Assembly ratings of 3-hours or less

Application and Design

The Model C/FSX is a square/rectangular UL Classified ceiling (radiation) damper, fabric blade style, approved for both steel duct and ductless installations in approved UL ceiling designs that incorporate/show a hinged door damper requiring fire/heat protection where HVAC components penetrate the ceiling membrane. This damper has a low profile design that allows for installation in ceiling with restricted space. The folded blade package allows for a maximum free area and lowest pressure drop. These dampers provide protection up to 24" x 24" (610mm x 610mm) openings.



Standard Construction

Frame: Roll formed. - 22 Ga. Galvanized Steel

Blades: 22 Ga. - Galvanized Steel and Insulated Fabric

Spring: Stainless Steel negator

Fusible Link: Replaceable 212°F (100°C) standard (others available)

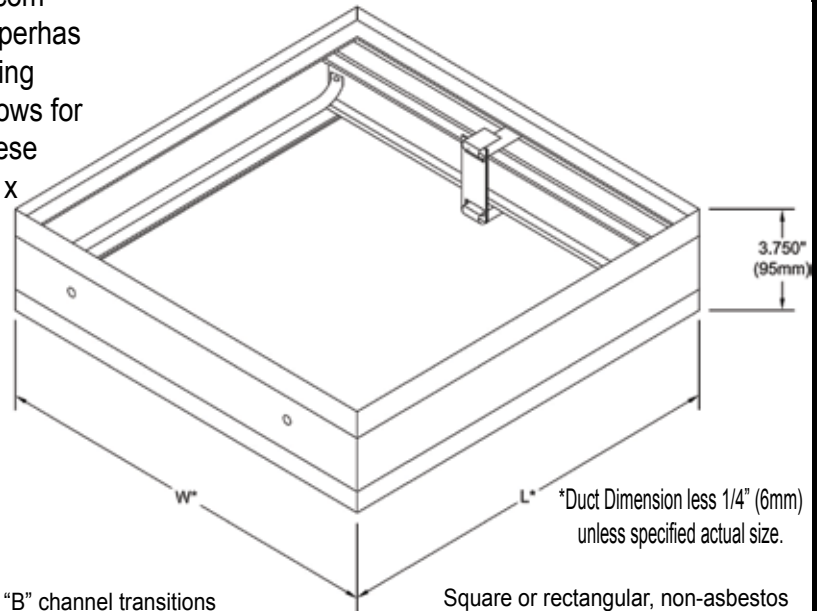

Designed and tested in accordance to standards: UL 555C, ULC S112.2. Labeled and listed by UL/ULC under File #R27747. They meet all the NFPA-90A, IBC Code, and other major code requirements for Ceiling (Radiation) Dampers.

Oversized damper with "B" channel transitions



Square or rectangular, non-asbestos

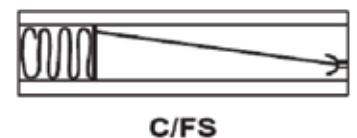

Thermal Blanket Skirt



C/FSX

(CK-2000 - Skirts) 10" Wide standard Damper with thermal blanket skirt for non-ducted return air penetrations

Standard Sizes (duct)		
Model	Min. Size	Max. Size
C/FS & C/FSX	4" X 4" (102mm X 102mm)	24" X 24" (610mm X 610mm)
C/FSB	4" X 4" (102mm X 102mm)	24" X 22" (610mm X 559mm)

SUGGESTED SPECIFICATION

Square and rectangular butterfly ceiling dampers shall be Model C/FS or C/FSB by CVS. Ceiling dampers shall bear the Underwriters' Laboratories label and be rated for both ducted (C/FS and C/FSB) or non-ducted (C/FSX) air systems. Ceiling dampers shall be of the non-asbestos, curtain type for maximum free area.

Manufacturer's Recommendations

All moving parts of the damper must be inspected and cycled once the first year and at intervals not greater than every 4 years or in accordance with the latest edition of NFPA 90A, 92A, local codes and the manufacturer. In addition, fuse links shall be removed and inspected for corrosion. Dry lubricants are recommended.

Job Name:	
Location:	
Architect:	
Engineer:	
Contractor:	

- MODEL C/FSX
- MODEL C/FSX-2F